

箱式配料混合机 MIX TANK

MIXTANK MTAseries

经济型容量计量机

川田的混合料箱能以给2种材料(主材与粉碎材)提供各种各样的安定混合比率,是经济型的机种

Economical, Simple Volumetric Feeder

KAWATA's MIXTANK is an economical, simple volumetric feeder which constantly feeds two kinds of materials (virgin and regrind) in volumetric feeder

安定的供给比率, 不受电压变化影响, 提供稳定比率

Constant Feeding Ratio, Feeding Materials at a Constant Ratio at any Voltage

简单操作, 可以根据期望比率来设定可变的全配合比率, 只要把自动运转开关调到 ON 上即可

Easy Operation, Set a Feeding Ratio and just Flip the "Automatic-operation" Switch on

简单构造, 为 2 种原料料箱与螺杆送料器的组合体

Simple Structure, Combination of the Two Material Tanks and Screw Feeder

节省能源, 200V 电压的情况下, 总电气容量为 0.12kW(200V)

Energy-saving, Total Electric Capacity: just 0.12kW(200V)

无维修保养, 由于没有过滤器等需点检的零件, 不需维修保养

Maintenance-free, Parts no such as Filters in need of Maintenance Inspection

规格 Specifications

型号/Model	MTA-60×60S-KS	MTA-125×125S-KS	MTA-250×250S-KS	
料箱容量/ Tank capacity (L)	主材 A/Material A	60	125	250
	粉碎材 B/Graule B	60	125	250
料箱材质/Tank material	JFE443CT/SUS304/AL			
配合方式/Feeding method	螺杆送料器/Screw feeder			
最大供给能力/ Feeding capacity Max. (kg/h)	主材 A/Material A	350		
	粉碎材 B/Graule B	255		
配比(A材: B材)/Mixing ratio(Material A: Graule B)	1: 0.1~0.7 (材料密度/ Material density A: 0.5g/cm ³ B: 0.5g/cm ³)			
异常表示/Alarm display	A材空杯 报警灯/Visual alarm (when material A is depleted)			
主断路器容量/Main breaker capacity (200V/2P)(A)	5			
总电气容量/Power supply (200/220V)(kW)	0.12 (单相/Single phase)			
机器重量/Weight (kg)	80	100	130	

选购件 Options

- 粉碎材(B材)的溢出口/Granule (B material) overflow
- 磁力架/Magnet
- 粉碎材(B材)的上限满杯料位计/Granule (B material) level gauge

TUMBLER KMseries

回转式混料机 ROTARY MIXER

料筒内面光洁度高, 清洗方便

Inner Surface of Tumbler has High Smoothness, Convenient for Cleaning

停止时料筒位置可任意调节, 并且不会自行滑动

Hopper Position can be freely Adjusted When Stopped, and cannot Slide by Itself

KM-50/100 有 1 处、KM-200 以上有 2 处安全保护的装置

1(KM-50,100) or 2(KM-200) Control Devices for Safety Protection

规格 Specifications

型号/Model	KM-50-KS	KM-100-KS	KM-200-KS	KM-500-KS	KM-1000-KS
筒体容量/Hopper capacity (L)	140	240	530	1480	2600
最大装料量/Max. load (kg)	50	100	200	500	1000
电机功率/Motor (kW)	0.75	1.1	2.2	5.5	15
主断路器容量/Main breaker capacity (200-220V)(A)	10		10/20	20/30	50/80
总电气容量/Power supply (200/220V)(kW)	0.75	1.1	2.2	5.5	15
涂装色/Paint color	日涂工 Y15-85A 半艶 JPMA Y15-85A, semigloss				
机器重量/Weight (kg)	250	370	710	1100	1800

外形尺寸图 Dimensions

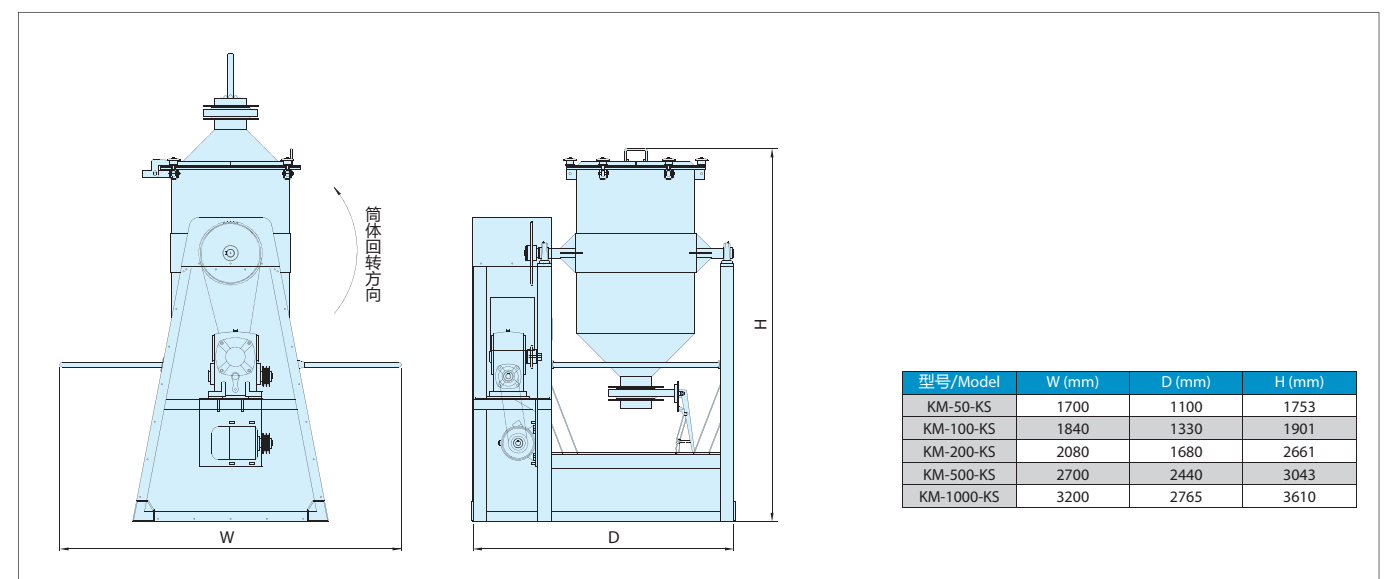

型号/Model	W (mm)	D (mm)	H (mm)
KM-50-KS	1700	1100	1753
KM-100-KS	1840	1330	1901
KM-200-KS	2080	1680	2661
KM-500-KS	2700	2440	3043
KM-1000-KS	3200	2765	3610

选购件 Options

- 操作架台/Operation stand
- 自动投料装置/Automatic Feeding
- 变频启动调速装置/Frequency Conversion Device (KM-1000-KS 包含变频启动调速装置)/(Frequency Conversion Device included in KM-1000-KS)



外形尺寸图 Dimensions

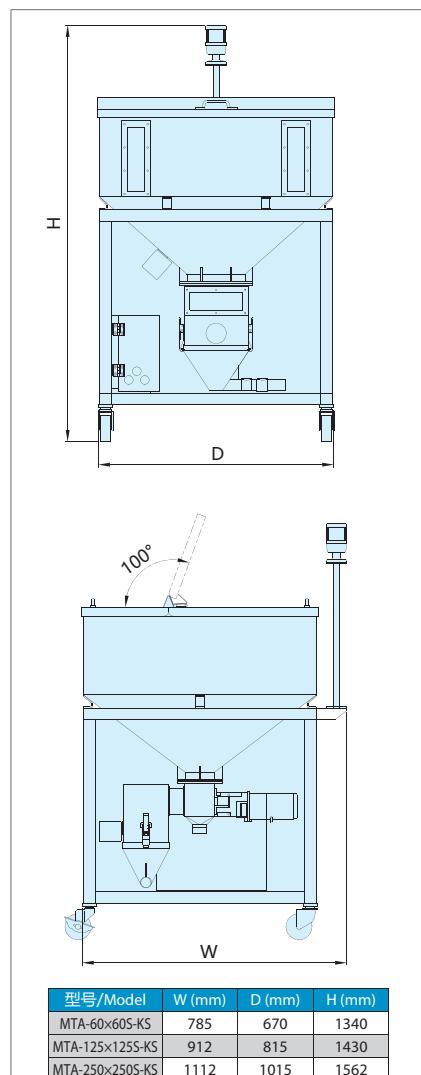

型号/Model	W (mm)	D (mm)	H (mm)
MTA-60×60S-KS	785	670	1340
MTA-125×125S-KS	912	815	1430
MTA-250×250S-KS	1112	1015	1562

